

Technical data sheet



Product features

Cooking range combined with electric convection oven GN 1/1 - 5x burner

Model	SAP Code	00002055
--------------	-----------------	----------



- Device type: Combined unit
- Power consumption of the zone 1 [kW]: 3,6
- Power consumption of the zone 2 [kW]: 3,6
- Power consumption of the zone 3 [kW]: 3,6
- Power consumption of the zone 4 [kW]: 3
- Power consumption of the zone 5 [kW]: 3
- Type of internal part of the appliance 1 (eg oven): Electric
- Type of internal part of the appliance 2 (eg oven): Hot air
- Protection of controls: IPX4
- Material: AISI 304 top plate, AISI 430 cladding

SAP Code	00002055	Power consumption of the zone 1 [kW]	3,6
Net Width [mm]	988	Power consumption of the zone 2 [kW]	3,6
Net Depth [mm]	609	Power consumption of the zone 3 [kW]	3,6
Net Height [mm]	900	Power consumption of the zone 4 [kW]	3
Net Weight [kg]	65.00	Power consumption of the zone 5 [kW]	3
Power electric [kW]	3.130	Type of internal part of the appliance 1 (eg oven)	Electric
Loading	230 V / 1N - 50 Hz	Type of internal part of the appliance 2 (eg oven)	Hot air
Power gas [kW]	16.800	Width of internal part [mm]	548
Type of gas	Natural gas, propane butane	Depth of internal part [mm]	360
Number of zones	5	Height of internal part [mm]	338

Technical data sheet



Technical drawing

Cooking range combined with electric convection oven GN 1/1 - 5x burner

Model

SAP Code

00002055

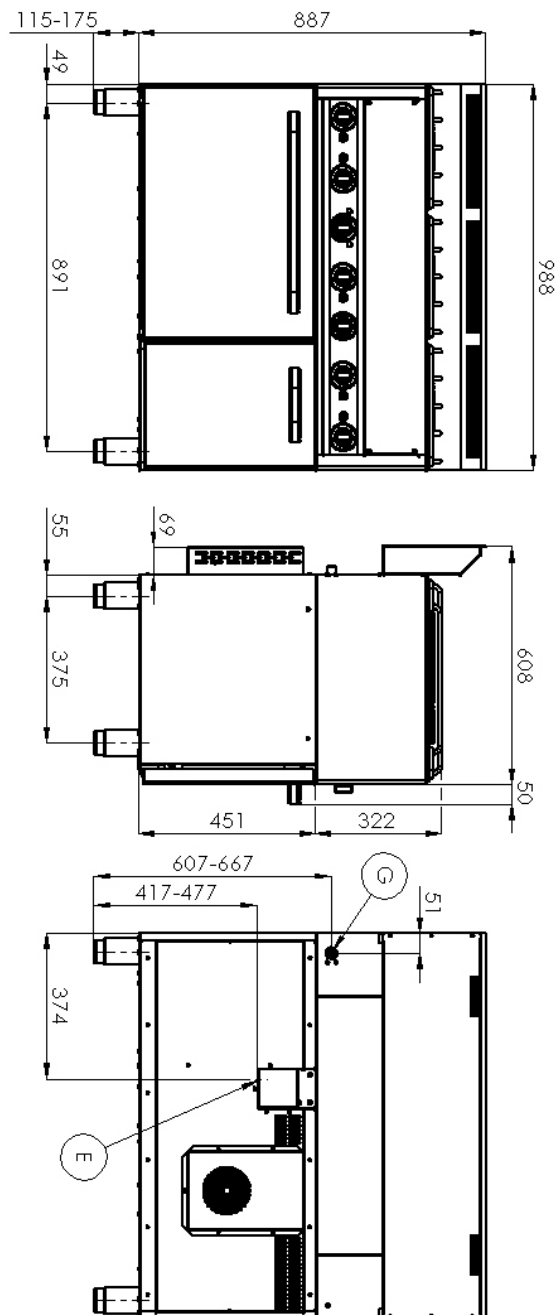

Technical data sheet



Product benefits

Cooking range combined with electric convection oven GN 1/1 - 5x burner

Model	SAP Code	00002055
--------------	-----------------	----------

1

Hygienic moldings of the top plate

absence of sharp corners and edges (potential places where dirt could stick)
smooth transitions

- easy quick cleaning

2

Hot air oven

hot air baking
high capacity and variability
all-stainless design

- suitable for meat, fish, baked pasta, white meat, sweet pastries
- long service life
- easy to clean

3

Degree of protection of the control elements IPX4

maintenance-free system
resistance to splash water
long life

- savings on service interventions
- greater job security for staff

4

All-stainless design

long life
resistance of a ground steel plate with a thickness of 10 mm

- savings on service interventions
- easy cleaning and maintenance of equipment

5

Safety element - thermocouple

safe service for staff
there is no unnecessary gas leakage
long life

- savings on service interventions
- easier and faster operation

Technical data sheet



Technical parameters

Cooking range combined with electric convection oven GN 1/1 - 5x burner

Model

SAP Code

00002055

1. SAP Code:

00002055

2. Net Width [mm]:

988

3. Net Depth [mm]:

609

4. Net Height [mm]:

900

5. Net Weight [kg]:

65.00

6. Gross Width [mm]:

705

7. Gross depth [mm]:

1055

8. Gross Height [mm]:

1120

9. Gross Weight [kg]:

79.00

10. Device type:

Combined unit

11. Construction type of device:

With substructure

12. Power electric [kW]:

3.130

13. Loading:

230 V / 1N - 50 Hz

14. Power gas [kW]:

16.800

15. Type of gas:

Natural gas, propane butane

16. Protection of controls:

IPX4

17. Material:

AISI 304 top plate, AISI 430 cladding

18. Indicators:

running and heating the oven

19. Worktop material:

AISI 304

20. Worktop Thickness [mm]:

0.80

21. Number of zones:

5

22. Power consumption of the zone 1 [kW]:

3,6

23. Power consumption of the zone 2 [kW]:

3,6

24. Power consumption of the zone 3 [kW]:

3,6

25. Power consumption of the zone 4 [kW]:

3

26. Power consumption of the zone 5 [kW]:

3

27. Number of power control stages:

6

28. Safety thermostat up to x ° C:

360

Technical data sheet



Technical parameters

Cooking range combined with electric convection oven GN 1/1 - 5x burner

Model

SAP Code

00002055

29. Adjustable feet:

Yes

35. Width of internal part [mm]:

548

30. Number of burners/hot plates:

5

36. Depth of internal part [mm]:

360

31. Type of gas cooking zones:

Powerfull

37. Height of internal part [mm]:

338

32. Oven Type:

electric hot air

38. Maximum temperature of the inner chamber [°C]:

300

33. Type of internal part of the appliance 1 (eg oven):

Electric

39. Minimum temperature of the inner chamber [°C]:

50

34. Type of internal part of the appliance 2 (eg oven):

Hot air